

UNIVERSITY OF CAMBRIDGE INTERNATIONAL EXAMINATIONS
International General Certificate of Secondary Education

MATHEMATICS

0580/04
0581/04

Paper 4 (Extended)

October/November 2005

Additional Materials: Answer Booklet/Paper
Electronic calculator
Geometrical instruments
Graph paper (3 sheets)
Mathematical tables (optional)
Tracing paper (optional)

2 hours 30 minutes

READ THESE INSTRUCTIONS FIRST

Write your answers and working on the separate Answer Booklet/Paper provided.
Write your name, Centre number and candidate number on all the work you hand in.
Write in dark blue or black pen on both sides of the paper.
You may use a soft pencil for any diagrams or graphs.
Do not use staples, paper clips, highlighters, glue or correction fluid.

Answer **all** questions.
At the end of the examination, fasten all your work securely together.
The number of marks is given in brackets [] at the end of each question or part question.

All working must be clearly shown. It should be done on the same sheet as the rest of the answer.
Marks will be given for working which shows that you know how to solve the problem even if you get the answer wrong.
The total of the marks for this paper is 130.
Electronic calculators should be used.
If the degree of accuracy is not specified in the question, and if the answer is not exact, give the answer to three significant figures.
Give answers in degrees to one decimal place.
For π use either your calculator value or 3.142.

This document consists of **8** printed pages.



1 A Spanish family went to Scotland for a holiday.

- (a) The family bought 800 pounds (£) at a rate of £1 = 1.52 euros (€).
How much did this cost in euros? [1]
- (b) The family returned home with £118 and changed this back into euros.
They received €173.46.
Calculate how many euros they received for each pound. [1]
- (c) A toy which costs €11.50 in Spain costs only €9.75 in Scotland.
Calculate, as a percentage of the cost in Spain, how much **less** it costs in Scotland. [2]
- (d) The total cost of the holiday was €4347.00.
In the family there were 2 adults and 3 children.
The cost for one adult was double the cost for one child.
Calculate the cost for one child. [2]
- (e) The **original** cost of the holiday was **reduced** by 10% to €4347.00.
Calculate the original cost. [2]
- (f) The plane took 3 hours 15 minutes to return to Spain.
The length of this journey was 2350 km.
Calculate the average speed of the plane in
- (i) kilometres per hour, [2]
- (ii) metres per second. [1]

2 **Answer the whole of this question on one sheet of graph paper.**

- (a) Draw and label x and y axes from -8 to $+8$, using a scale of 1 cm to 1 unit on each axis. [1]
- (b) Draw and label triangle ABC with $A(2, 2)$, $B(5, 2)$ and $C(5, 4)$. [1]
- (c) On your grid:
- (i) translate **triangle** ABC by the vector $\begin{pmatrix} 3 \\ -9 \end{pmatrix}$ and label this image $A_1B_1C_1$; [2]
- (ii) reflect **triangle** ABC in the line $x = -1$ and label this image $A_2B_2C_2$; [2]
- (iii) rotate **triangle** ABC by 180° about $(0, 0)$ and label this image $A_3B_3C_3$. [2]
- (d) A stretch is represented by the matrix $\begin{pmatrix} 1.5 & 0 \\ 0 & 1 \end{pmatrix}$.
- (i) Draw the image of **triangle** ABC under this transformation. Label this image $A_4B_4C_4$. [3]
- (ii) Work out the inverse of the matrix $\begin{pmatrix} 1.5 & 0 \\ 0 & 1 \end{pmatrix}$. [2]
- (iii) Describe **fully** the single transformation represented by this inverse. [3]

NOT TO
SCALE

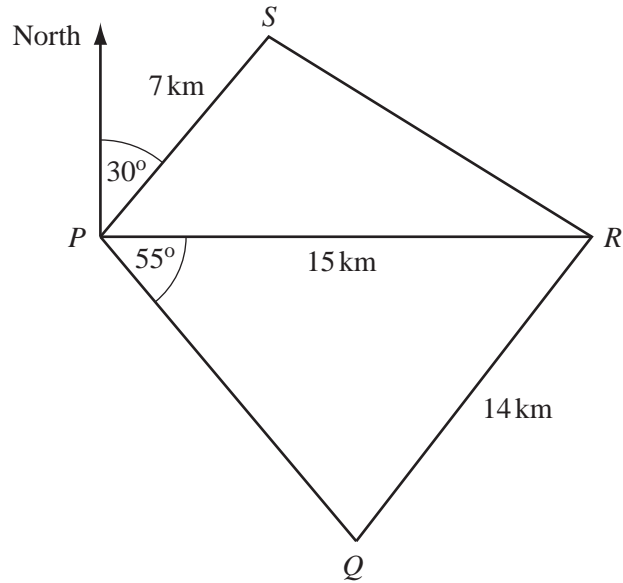

The quadrilateral $PQRS$ shows the boundary of a forest.
A straight 15 kilometre road goes due East from P to R .

- (a) The bearing of S from P is 030° and $PS = 7$ km.
- (i) Write down the size of angle SPR . [1]
- (ii) Calculate the length of RS . [4]
- (b) Angle $RPQ = 55^\circ$ and $QR = 14$ km.
- (i) Write down the bearing of Q from P . [1]
- (ii) Calculate the acute angle PQR . [3]
- (iii) Calculate the length of PQ . [3]
- (c) Calculate the area of the forest, correct to the nearest square kilometre. [4]

- 4 (a) All 24 students in a class are asked whether they like football and whether they like basketball. Some of the results are shown in the Venn diagram below.

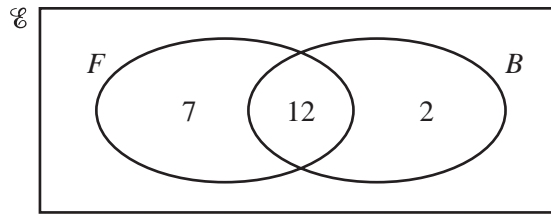

$\mathcal{U} = \{\text{students in the class}\}$.

$F = \{\text{students who like football}\}$.

$B = \{\text{students who like basketball}\}$.

- (i) How many students like both sports? [1]
- (ii) How many students do not like either sport? [1]
- (iii) Write down the value of $n(F \cup B)$. [1]
- (iv) Write down the value of $n(F' \cap B)$. [1]
- (v) A student from the class is selected at random.
What is the probability that this student likes basketball? [1]
- (vi) A student who likes football is selected at random.
What is the probability that this student likes basketball? [1]
- (b) Two students are selected at random from a group of 10 boys and 12 girls.
Find the probability that
- (i) they are both girls, [2]
- (ii) one is a boy and one is a girl. [3]

5 Answer the whole of this question on one sheet of graph paper.

$$f(x) = 1 - \frac{1}{x^2}, \quad x \neq 0.$$

(a)

x	-3	-2	-1	-0.5	-0.4	-0.3	0.3	0.4	0.5	1	2	3
$f(x)$	p	0.75	0	-3	-5.25	q	q	-5.25	-3	0	0.75	p

Find the values of p and q . [2]

- (b) (i) Draw an x -axis for $-3 \leq x \leq 3$ using 2 cm to represent 1 unit and a y -axis for $-11 \leq y \leq 2$ using 1 cm to represent 1 unit. [1]
- (ii) Draw the graph of $y = f(x)$ for $-3 \leq x \leq -0.3$ and for $0.3 \leq x \leq 3$. [5]
- (c) Write down an integer k such that $f(x) = k$ has no solutions. [1]

- (d) On the same grid, draw the graph of $y = 2x - 5$ for $-3 \leq x \leq 3$. [2]
- (e) (i) Use your graphs to find solutions of the equation $1 - \frac{1}{x^2} = 2x - 5$. [3]
- (ii) Rearrange $1 - \frac{1}{x^2} = 2x - 5$ into the form $ax^3 + bx^2 + c = 0$, where a , b and c are integers. [2]
- (f) (i) Draw a tangent to the graph of $y = f(x)$ which is parallel to the line $y = 2x - 5$. [1]
- (ii) Write down the equation of this tangent. [2]

6

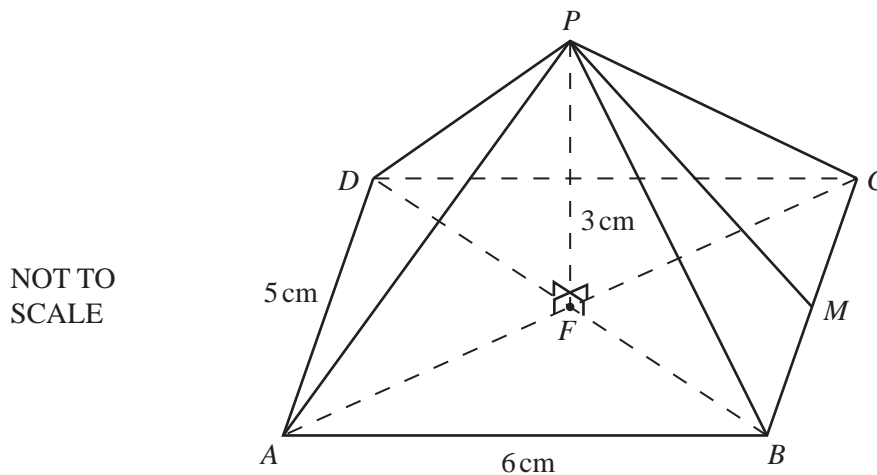

The diagram shows a pyramid on a rectangular base $ABCD$, with $AB = 6$ cm and $AD = 5$ cm.
 The diagonals AC and BD intersect at F .
 The vertical height $FP = 3$ cm.

- (a) How many planes of symmetry does the pyramid have? [1]
- (b) Calculate the volume of the pyramid.
 [The volume of a pyramid is $\frac{1}{3} \times \text{area of base} \times \text{height}$.] [2]
- (c) The mid-point of BC is M .
 Calculate the angle between PM and the base. [2]
- (d) Calculate the angle between PB and the base. [4]
- (e) Calculate the length of PB . [2]

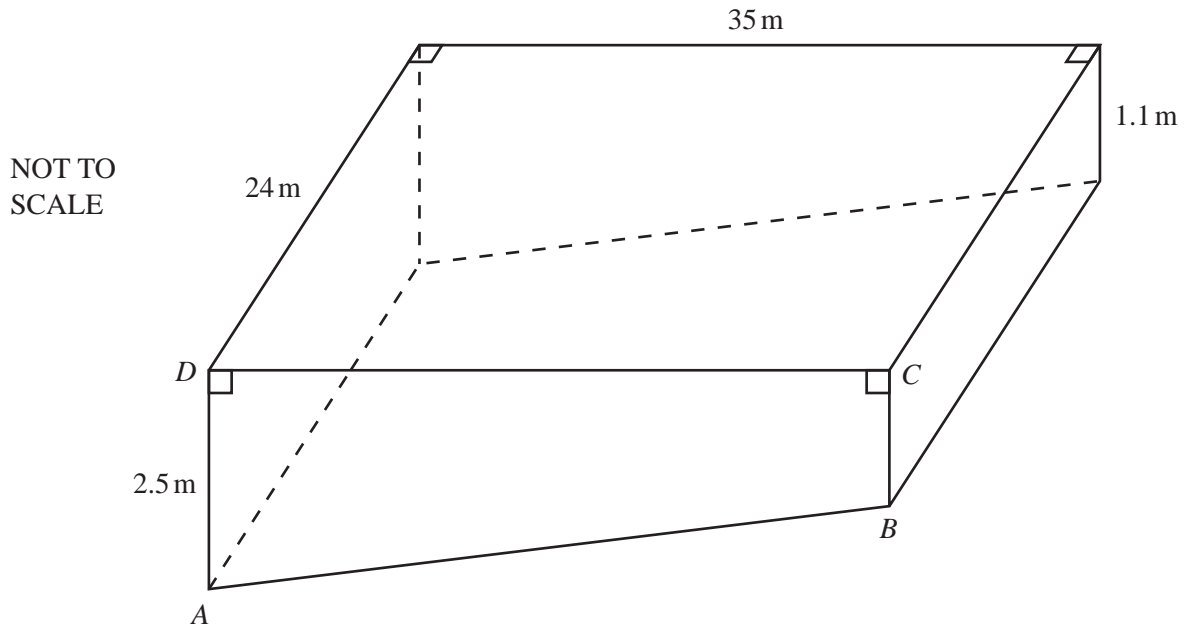

The diagram shows a swimming pool of length 35 m and width 24 m.
A cross-section of the pool, $ABCD$, is a trapezium with $AD = 2.5$ m and $BC = 1.1$ m.

(a) Calculate

(i) the area of the trapezium $ABCD$, [2]

(ii) the volume of the pool, [2]

(iii) the number of litres of water in the pool, when it is full. [1]

(b) $AB = 35.03$ m correct to 2 decimal places.
The sloping rectangular floor of the pool is painted.
It costs \$2.25 to paint one square metre.

(i) Calculate the cost of painting the floor of the pool. [2]

(ii) Write your answer to **part (b)(i)** correct to the nearest hundred dollars. [1]

(c) (i) Calculate the volume of a cylinder, radius 12.5 cm and height 14 cm. [2]

(ii) When the pool is emptied, the water flows through a cylindrical pipe of radius 12.5 cm.
The water flows along this pipe at a rate of 14 centimetres per second.
Calculate the time taken to empty the pool.
Give your answer in days and hours, correct to the nearest hour. [4]

- 8 (a) (i) The cost of a book is $\$x$.
Write down an expression in terms of x for the number of these books which are bought for $\$40$. [1]
- (ii) The cost of each book is increased by $\$2$.
The number of books which are bought for $\$40$ is now one less than before.
Write down an equation in x and show that it simplifies to $x^2 + 2x - 80 = 0$. [4]
- (iii) Solve the equation $x^2 + 2x - 80 = 0$. [2]
- (iv) Find the original cost of one book. [1]
- (b) Magazines cost $\$m$ each and newspapers cost $\$n$ each.
One magazine costs $\$2.55$ more than one newspaper.
The cost of two magazines is the same as the cost of five newspapers.
- (i) Write down two equations in m and n to show this information. [2]
- (ii) Find the values of m and n . [3]
-

QUESTION 9 is on page 8.

9

Answer the whole of this question on one sheet of graph paper.

The heights (h cm) of 270 students in a school are measured and the results are shown in the table.

h	Frequency
$120 < h \leq 130$	15
$130 < h \leq 140$	24
$140 < h \leq 150$	36
$150 < h \leq 160$	45
$160 < h \leq 170$	50
$170 < h \leq 180$	43
$180 < h \leq 190$	37
$190 < h \leq 200$	20

- (a) Write down the modal group. [1]
- (b) (i) Calculate an estimate of the mean height. [4]
- (ii) Explain why the answer to **part (b)(i)** is an estimate. [1]
- (c) The following table shows the cumulative frequencies for the heights of the students.

h	Cumulative frequency
$h \leq 120$	0
$h \leq 130$	p
$h \leq 140$	q
$h \leq 150$	r
$h \leq 160$	120
$h \leq 170$	170
$h \leq 180$	213
$h \leq 190$	250
$h \leq 200$	270

- Write down the values of p , q and r . [2]
- (d) Using a scale of 1cm to 5 units, draw a horizontal h -axis, starting at $h = 120$.
Using a scale of 1cm to 20 units on the vertical axis, draw a cumulative frequency diagram. [5]
- (e) Use your diagram to find
- (i) the median height, [1]
- (ii) the upper quartile, [1]
- (iii) the inter-quartile range, [1]
- (iv) the 60th percentile. [1]
- (f) All the players in the school's basketball team are chosen from the 30 tallest students.
Use your diagram to find the least possible height of any player in the basketball team. [2]

Permission to reproduce items where third-party owned material protected by copyright is included has been sought and cleared where possible. Every reasonable effort has been made by the publisher (UCLES) to trace copyright holders, but if any items requiring clearance have unwittingly been included, the publisher will be pleased to make amends at the earliest possible opportunity.

University of Cambridge International Examinations is part of the University of Cambridge Local Examinations Syndicate (UCLES), which is itself a department of the University of Cambridge.